

PHSK-2L



Universal Dual Temperature, Carbon Fibre Seat Heater Kit Installation Guide



ECHOMASTER
PRO

Installation Guide



PHSK-2L

Universal Dual Temp
Carbon Fibre Seat Heater Kit

Introduction

Thank you for purchasing your EchoMaster Pro Universal Dual Temp Carbon Fibre Seat Heater Kit.

EchoMaster seat heaters are designed to work fast, minimising the time that you have to deal with discomfort from cold seats.

With adjustable temperature settings and an ON/OFF switch, you have full control over your seat heating experience.

General Information

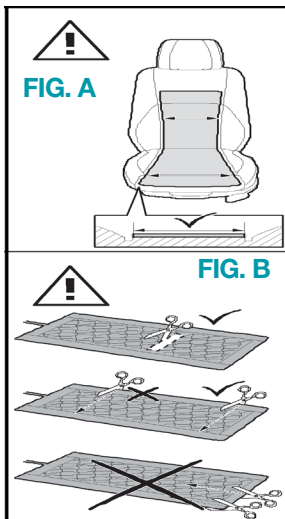

Do NOT install PHSK-2L if:

- ▶ The OEM seat covers are glued to the foam
- ▶ The flat centre part of the seat is below 10" wide

Be sure to disconnect the vehicle's battery. (check to make sure you have radio codes if equipped)

DO NOT modify the factory seat covers or seat cover seams on seats equipped with side airbags.

The heating elements should only be installed in the centre, flat portions of the seat.

Professional installation is recommended. Improper installation can result in element malfunction, causing injury or reliability issues.

DO NOT modify or replace any components of the kit with parts not supplied. Be sure to mount and secure the heating element to the seat foam, and that it is free of bends and creases. Damaged elements should **NOT** be installed and should be replaced.

PHSK-2L

Universal Dual Temp
Carbon Fibre Seat Heater Kit



General Information (continued)

This heating element is designed for use on 12 volt vehicles and should not be used on any other vehicle with a different operating voltage such as 24 volt or 6 volt vehicles. All power connections should be made to an IGN source.

DO NOT cut the heating element width wise, as this will damage the element and cause malfunction. (fig. B)

DO NOT modify the harness in any way. Be sure that the harness is routed and secured in a way to avoid sharp objects, metal edges, or any object that could chafe the wire harness.

Make sure the seat moves freely from front to rear after installation.

Be sure that the seat foam is clean and free of contaminants such as grease or silicone. Allow the elements proper time for the adhesion process in order to ensure the best adhesion. (typically 48 hours) Do not reuse elements after they have been adhered to a surface.

DO NOT allow the heating element to come into contact with the with conductive surfaces in the seats frame, metal bars or hog rings or short circuit may occur.

Seat cover material will affect the heating time. Customers should be notified about the location of the fuses used in the installation process in case of failure.

DO NOT install this product over sensors, airbags, or other parts related to the SRS airbag system.

Installation Guide



PHSK-2L

Universal Dual Temp
Carbon Fibre Seat Heater Kit

Box Contents

1. 2 x Heated Carbon Fibre Heating Pads
2. Illuminated High/Low Switch
3. Wire Harness Assembly
4. Pole SPDT Relay
5. Fuse Holder (7.5A Fuse)
6. Heat Transfer Tape
7. Zip Ties

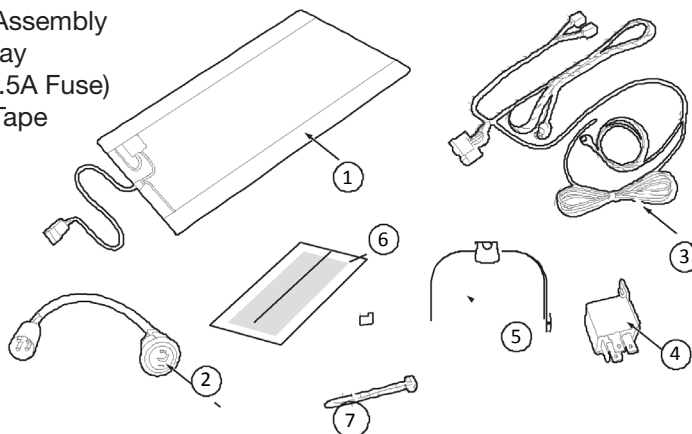

Installation

Park vehicle on a level surface with hand brake engaged.

Disconnect the vehicles battery. (check to make sure that you have radio codes if equipped)

Unplug all harnesses attached to the underside of the seat. Remove seat bolts.

Remove the seat from the vehicle taking care not to damage any of the interior panels during removal.

Remove the seat covers by carefully detaching the “J” clips located at the seat back’s seam or on the underside of the seat’s base.

CAUTION: the metal that the “J” clip is attached to may be very sharp. Test fit the heating elements against their respective seat cushion and mark any location that need to be cut.

PHSK-2L

Universal Dual Temp
Carbon Fibre Seat Heater Kit



Installation (continued)

If required, carefully cut 2 holes vertically or horizontally, holes should not exceed 1" in diameter. DO NOT cut more than two holes in each heating element.

Seat heating elements may be trimmed to fit seat cushions length wise. If the element is too long to fit the seat simply trim the element with scissors to fit desired area.

DO NOT cut the heating element width wise.

Remove the adhesive backing from the heating element and carefully adhere to the seat cushion in the desired location. Be sure to align any mounting holes that you have created.

If working with "rod" style seat covers, insulate the rod from contact with the heating element using a strip of the provided adhesive contact tape. If working with a "velcro" style seat cover this is not needed.

Reinstall the seat cover and replace the "J" clips to their original location. Locate 12 volt power source that is capable of supplying 7.5 amps of continuous power. EchoMaster recommends using an IGN power source that rests at 0 volts when the key is not in the RUN position.

Once you have found a suitable power source, route the harness in a safe manner from under the seat to the desired power source. Be sure that harness is fastened to vehicle using zip ties.

Find a suitable location for the seat heater switches to be mounted in the side of the seat, dash, or centre console between the driver and passenger seats. Drill a 13/16" hole (21mm) at the desired switch location. Route the switch harness through the hole and plug into main harness.

Push the switch into the hole and snap into place firmly.

Reinstall the seats in to the vehicle. Plug all removed connectors back into seat, and plug the EchoMaster seat heater harness to the heater elements.

Installation Guide



PHSK-2L

Universal Dual Temp
Carbon Fibre Seat Heater Kit

Installation (continued)

Make the connection of the EchoMaster provided harness power **(RED)** to the IGN source previously identified, and connect the ground wire **(BLACK)** to good chassis ground on the vehicle.

Reconnect the battery terminals, and turn the key to the IGN or RUN position. Test the system to ensure proper functionality

UP = High

Middle = OFF

Down = Low

Operating Instructions

The PHSK-2L is designed to be operated only when the seat is occupied. It is imperative that the person occupying the seat is able to feel temperature differences and be able to react to them.

Those who have difficulty feeling temperature differences, such as paraplegic, young or elderly people should **NOT** use this product.

The PHSK-2L should not be switched on and left unattended. Caution should be used to ensure no accidental activation of the seat heater switch.

IF the occupant feels excessive/undesired heat from the seat heater, the PHSK-2L should be switched off immediately.

External seat covers, blankets, towels, rugs or coverings other than the original seat cover should not be placed on the seat while the PHSK-2L is in the "ON" position.

WARNING: The PHSK-2L should not be exposed to liquids of any kind. If the heater has been exposed to spills or liquids, ample time should be given for the heaters to dry before continuing use. Otherwise, failure or injury may occur.

PHSK-2L

Universal Dual Temp
Carbon Fibre Seat Heater Kit



Operating Instructions (continued)

“HIGH” Temperature Setting:

- The PHSK-2L is switched ‘ON’ by pressing the switch up. This will engage the seat heater in the HIGH temperature setting. When in the HIGH setting the LED will illuminate RED.

LOW Temperature Setting:

- The PHSK-2L is also switched ‘ON’ by pressing the switch down. This will engage the seat heater in the LOW temperature setting. When in the LOW setting the LED will illuminate AMBER.

Note:

The seat heating element is switched “ON” by moving the switch upwards or downwards from its centre OFF position. The heat will be noticeable within 4 - 5 minutes.

The heating time can vary according to the type of seat cover material and kind of clothing or coat that is being worn. The heating must be switched to the ‘Low’ setting in order to avoid overheating, when the desired temperature has been achieved.

Installation Guide



PHSK-2L

Universal Dual Temp
Carbon Fibre Seat Heater Kit

Wiring Diagram

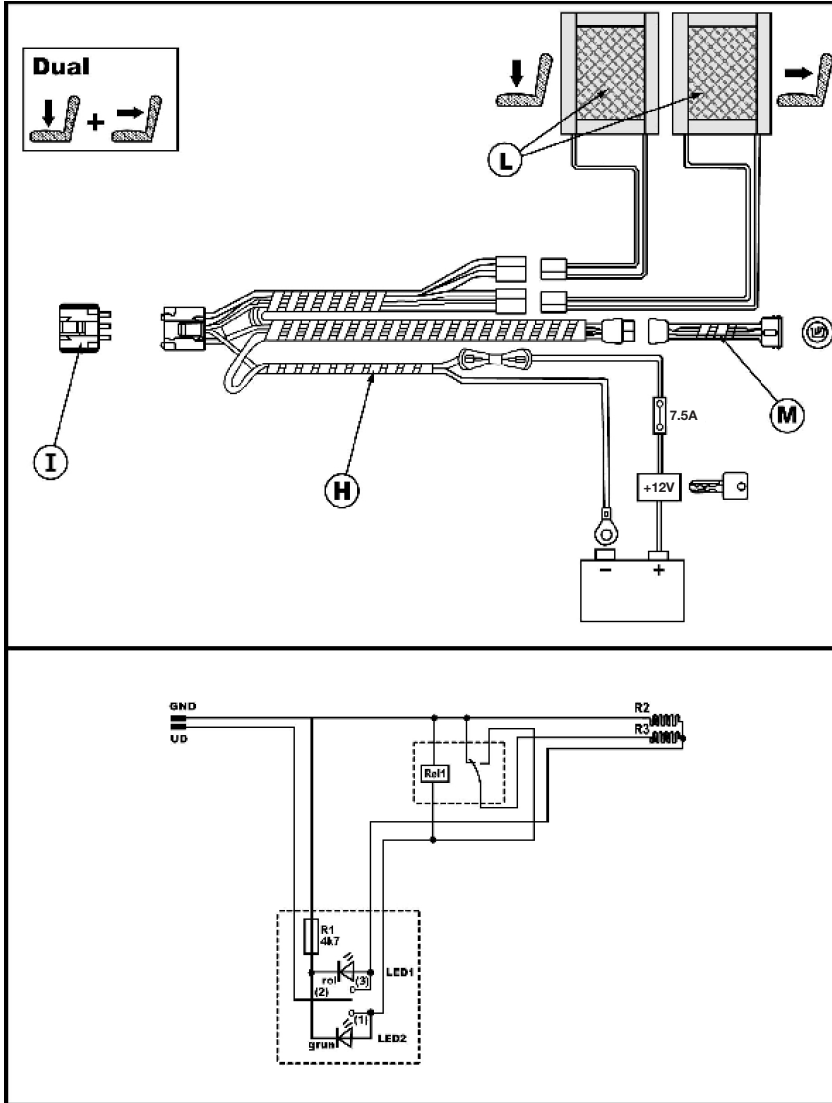

PHSK-2L

Universal Dual Temp
Carbon Fibre Seat Heater Kit



Troubleshooting

Problem	Solution
The seat heater does not function although the switch is in the HIGH or LOW position and the LED is not illuminated.	Verify that the system's main power fuse is not blown. Replace if blown.
The LED is not illuminating on the switch, but the seat heater is functioning properly.	The LED in the switch is defective.
The seat heater is not functioning and the LED is illuminated.	The temperature of the seat heater is too high and may be in protection mode. Switch the heater off and allow to cool.
The distribution of heat is not even between the seat bottom and back	Discontinue use and consult a professional installer
The fuse continues to blow repeatedly.	Check system wiring for short circuit, and contact a professional installer.

Installation Guide



PHSK-2L

Universal Dual Temp
Carbon Fibre Seat Heater Kit

Installation Guide

PHSK-2L

Universal Dual Temp
Carbon Fibre Seat Heater Kit





Woolmer Way, Bordon, Hampshire, United Kingdom
email - technical.eu@aampglobal.com (Europe)
tel - +44(0)1420 487110 (Sales) - +44(0)1420 470618 (Technical)



EchoMaster is a Power Brand of AAMP Global.
Echomaster.com

REV1.1